

Specifier's Reference

Project
Type
Model No.
Comments

application

- A highly efficient, visually comfortable, architecturally styled recessed LED luminaire designed with a minimalistic strategy to achieve sustainable objectives.
- Low profile configuration is only 2-11/16" high and is compatible with virtually any plenum.
- Clean, modern design offers a fresh variation on the popular dual chamber theme and provides architectural styling compatible with virtually any area.
- Soft opal diffusers with large luminous area minimize apparent brightness and provide high visual comfort perfect for a wide variety of general lighting applications like offices, schools, retail, or healthcare.
- Four lumen packages over a wide range (2,700 to 4,400 initial delivered lumens) provide significant application flexibility over light levels and/or luminaire spacing.
- A high lumen package can be used in conjunction with wide luminaire spacing to reduce luminaire quantities and overall cost while maintaining good uniformity.
- High efficiency source and luminaire design create significant energy savings over conventional solutions. Recommended light levels can frequently be achieved with lighting power densities of 0.5 to 0.85 Watts per square foot, complying with any known energy code.
- Directs a controlled amount of light to the higher angles in the room to balance the brightness of the surfaces and eliminate "cave effect" while creating the impression of a larger, brighter space without glare.
- Excellent color rendering with a CRI of 80.
- LEDs are an excellent source for use with controls since dimming or frequent switching does not degrade the performance or life of the source. Integral or external sensors are available for use.
- Designed for use with standard Grid (NEMA "G") or Narrow Grid (NEMA "NFG") ceiling T-bars. Drywall or plaster requirements can be accommodated by using an FMA22 "F" mounting frame (sold separately.)
- Listed for use in insulated ceilings (Type IC.)

construction/finish

- Uncomplicated design is well under 3" in depth and only requires a few parts outside of the electrical system and hardware, creating several benefits:
 - Less material required
 - Less packaging required
 - Reduced weight
 - Less energy required for construction and assembly
 - More luminaires can be shipped per truck to reduce fuel use and emissions

- Luminaire is painted after fabrication with a matte white polyester powder coating for a high quality, durable finish with no unfinished edges to create an installation hazard or potential for corrosion.

- T-bar grid clips are included for easy installation

electrical

- Integral sensor options for occupancy sensing and/ or daylight harvesting are available for additional energy savings with no reduction of life or increase in installation labor.
- Total luminaire efficacy as high as 86 LPW (lumens per Watt) significantly reduces energy usage compared to conventional 2x2 sources.
- Driver and LED boards are easily accessible from below without tools. Multiple LED boards are individually replaceable if needed via plug-in connectors to ensure long service life.
- 0-10V dimming and emergency options are available to add even more application flexibility. Emergency models require a top mounted driver enclosure that increases luminaire depth.
- Five year luminaire warranty includes LED boards and driver (emergency driver and batteries have a three year warranty in models so equipped.)
- High efficiency LEDs have a minimum 50,000 hour rated life (L₇₀.)
- ETL listed to UL and CSA standards, suitable for damp locations.

enclosure

- Dual chamber configuration utilizes two diffusers with large surface area for brightness control.
- Opal diffusers provide soft, comfortable lighting while maintaining high efficiency.
- Diffusers require no frames or fasteners and can be easily removed from below without tools if needed.

Green Choice: 2DLG34L840-2-D-UNV-DAYOCC

2	DL	G	-	2	-	D	-	-
<u>Width</u> 2 - 2'	<u>Family</u> DL - DuaLED	<u>Ceiling Type</u> G - Grid		<u>Length</u> 2 - 2'		<u>Diffusers</u> D - Diffuse (Opal)		<u>Voltage</u> UNV - Universal voltage, 120-277 volt 347
		<u>Source</u>						<u>Options</u>
		27L840 - 2700 delivered lumens, 80 CRI, 4000K 34L840 - 3400 delivered lumens, 80 CRI, 4000K 38L840 - 3800 delivered lumens, 80 CRI, 4000K 44L840 - 4400 delivered lumens, 80 CRI, 4000K						CC - Custom Color F1 - 3/8" Flex, 3 Wire 18 gauge F2 - 3/8" Flex, 4 Wire 18 gauge GLR1 - Fusing, Fast Blow DIM - 0-10V dimming driver (34L840 and 44L840 models only) EMLED16 - Integral emergency battery pack (1600 delivered lumens, requires ballast enclosure on top of luminaire) OCC - Integral sensor, occupancy DAY - Integral sensor, daylighting (34L840 and 44L840 models only) DAYOCC - Integral sensor, daylighting and occupancy (34L840 and 44L840 models only)

Accessories

FMA22 - 2'x2' "F" mounting frame for NEMA "F" mounting

energy data

Model	Initial Delivered Lumens at 25°C Ambient	Input Power	Lumens Per Watt
2DLG27L840-2-D	2659	31W	86LPW
2DLG34L840-2-D	3368	39W	86LPW
2DLG38L840-2-D	3787	45W	84LPW
2DLG44L840-2-D	4396	54W	81LPW

Fluorescent Configuration	Approx. Total Delivered Lumens	DuaLED Equivalent*
2 lamp T8 31U6	3,500	2DLG34L840-2-D
2 lamp T8 31U1	3,900	2DLG38L840-2-D
3 lamp T8 31U1	5,500	n/a max. lumens would be 2DLG44L840-2-D
2 lamp T12 40U6	2,800	2DLG27L840-2-D
3 lamp T12 40U3	3,800	2DLG38L840-2-D

Fluorescent Configuration	Approx. Total Delivered Lumens	DuaLED Equivalent
2 lamp T8 17W	2,000	2DLG27L840-2-D
3 lamp T8 17W	2,850	2DLG27L840-2-D
4 lamp T8 17W	3,650	2DLG34L840-2-D
2 lamp CF40	4,800	2DLG44L840-2-D
3 lamp CF40	6,900	n/a, max. lumens would be 2DLG44L840-2-D

*DuaLED equivalent will provide similar delivered lumens and light levels. Analysis to determine appropriate light levels for the space is highly recommended.

dimensions

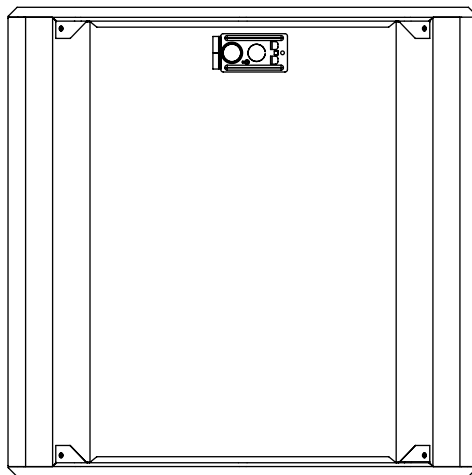
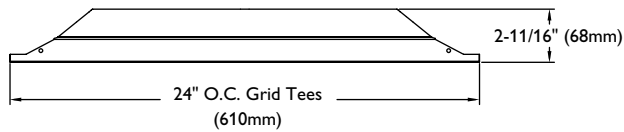

ceiling configuration

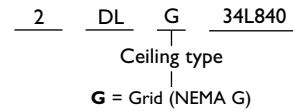

SIDE

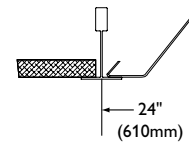

(NEMA Type G)
Lay-in acoustical ceilings using exposed grid suspension, with tees for luminaires on 24" x 24" spacing.

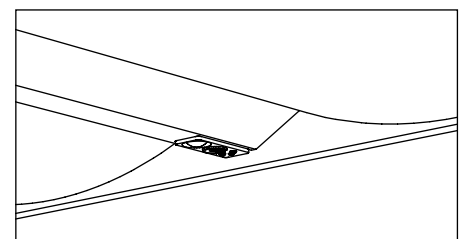
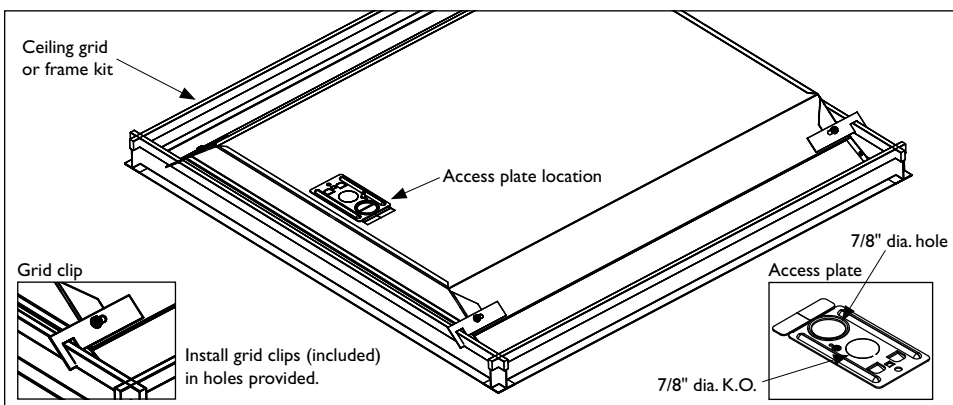

Integral sensor options are available offering occupancy sensing, continuous dimming daylight sensing, or occupancy and daylight sensing together.

photometry

2x2 DualLED, 2700 delivered lumens

LER – 86

Catalog No. 2DLG27L840-2-D Test No. 29947 S/MH 1.3 Lamp Type 30WLED Lumens/Lamp 2659 Input Watts 31 Comparative yearly lighting energy cost per 1000 lumens – \$2.79 based on 3000 hrs. and \$.08 pwr KWH. The photometric results were obtained in the Philips Day-Brite laboratory which is NVLAP accredited by the National Institute of Standards and Technology. Photometric values based on test performed in compliance with LM-79.	Candlepower				Light Distribution			Average Luminance			
	Angle	End	45	Cross	Degrees	Lumens	% Luminaire	Angle	End	45°	Cross
	0	937	937	937	0-30	726	27.3	45	2325	2359	2401
	5	931	934	934	0-40	1188	44.7	55	2205	2271	2327
	10	917	921	921	0-60	2100	79.0	65	2063	2139	2152
	15	896	899	902	0-90	2660	100.0	75	1830	1768	1747
	20	864	871	874				85	1235	1112	1112
	25	826	834	839							
	30	783	788	797							
	35	730	739	747							
	40	673	682	695							
	45	611	620	631							
	50	544	555	568							
	55	470	484	496							
	60	402	410	417							
	65	324	336	338							
	70	250	256	252							
75	176	170	168								
80	104	96	91								
85	40	36	36								

2x2 DualLED, 3400 delivered lumens

LER – 86

Catalog No. 2DLG34L840-2-D Test No. 29946 S/MH 1.3 Lamp Type 38WLED Lumens/Lamp 3368 Input Watts 39 Comparative yearly lighting energy cost per 1000 lumens – \$2.79 based on 3000 hrs. and \$.08 pwr KWH. The photometric results were obtained in the Philips Day-Brite laboratory which is NVLAP accredited by the National Institute of Standards and Technology. Photometric values based on test performed in compliance with LM-79.	Candlepower				Light Distribution			Average Luminance			
	Angle	End	45	Cross	Degrees	Lumens	% Luminaire	Angle	End	45°	Cross
	0	1185	1185	1185	0-30	919	27.3	45	2930	2999	3048
	5	1178	1182	1182	0-40	1505	44.7	55	2801	2885	2960
	10	1161	1165	1166	0-60	2659	79.0	65	2604	2687	2719
	15	1133	1137	1142	0-90	3368	100.0	75	2298	2298	2194
	20	1096	1102	1107				85	1575	1482	1451
	25	1046	1059	1062							
	30	988	999	1007							
	35	923	934	948							
	40	851	863	879							
	45	770	788	801							
	50	685	703	719							
	55	597	615	631							
	60	506	522	529							
	65	409	422	427							
	70	314	321	321							
75	221	221	211								
80	133	121	111								
85	51	48	47								

2x2 DualLED, 3800 delivered lumens

LER – 84

Catalog No. 2DLG38L840-2-D Test No. 29948 S/MH 1.3 Lamp Type 45WLED Lumens/Lamp 3787 Input Watts 45 Comparative yearly lighting energy cost per 1000 lumens – \$2.86 based on 3000 hrs. and \$.08 pwr KWH. The photometric results were obtained in the Philips Day-Brite laboratory which is NVLAP accredited by the National Institute of Standards and Technology. Photometric values based on test performed in compliance with LM-79.	Candlepower				Light Distribution			Average Luminance			
	Angle	End	45	Cross	Degrees	Lumens	% Luminaire	Angle	End	45°	Cross
	0	1335	1335	1335	0-30	1034	27.3	45	3303	3360	3436
	5	1326	1330	1331	0-40	1693	44.7	55	3143	3242	3312
	10	1307	1312	1314	0-60	2991	79.0	65	2916	3012	3082
	15	1276	1281	1285	0-90	3787	100.0	75	2558	2578	2464
	20	1232	1239	1247				85	1791	1544	1636
	25	1176	1185	1197							
	30	1111	1126	1139							
	35	1039	1049	1070							
	40	954	972	989							
	45	868	883	903							
	50	772	788	810							
	55	670	691	706							
	60	566	585	597							
	65	458	473	484							
	70	357	366	360							
75	246	248	237								
80	148	137	131								
85	58	50	53								

photometry

2x2 DualLED, 4400 delivered lumens

LER – 81

Catalog No.	2DLG44L840-2-D	Candlepower				Light Distribution			Average Luminance			
		Angle	End	45	Cross	Degrees	Lumens	% Luminaire	Angle	End	45°	Cross
Test No.	29944	0	1551	1551	1551	0-30	1202	27.3	45	3836	3897	3996
S/MH	1.3	5	1542	1545	1546	0-40	1967	44.8	55	3645	3767	3847
Lamp Type	53WLED	10	1519	1524	1527	0-60	3476	79.1	65	3375	3547	3572
Lumens/Lamp	4396	15	1481	1489	1494	0-90	4396	100.0	75	2953	2974	2859
Input Watts	54	20	1432	1442	1448				85	1976	1698	1729
		25	1366	1381	1390							
		30	1290	1303	1321							
		35	1207	1225	1241							
		40	1112	1129	1147							
		45	1008	1024	1050							
		50	898	923	940							
		55	777	803	820							
		60	657	684	696							
		65	530	557	561							
		70	409	423	420							
		75	284	286	275							
		80	167	157	147							
		85	64	55	56							

EFFECTIVE FLOOR CAVITY REFLECTANCE 20 PER (pfc=0.20)									
pcc	80			70			50		
	70	50	30	70	50	30	50	30	
pw									
RCR									
0	118	118	118	115	115	115	111	111	
1	109	104	100	106	102	97	96	93	
2	98	91	83	95	89	81	84	80	
3	90	80	70	88	78	69	75	68	
4	81	69	61	80	68	60	67	58	
5	76	63	54	73	61	53	59	52	
6	69	56	47	68	56	46	54	46	
7	65	51	41	63	50	41	48	40	
8	59	46	38	58	46	38	45	36	
9	56	42	34	55	41	34	40	34	
10	53	40	32	52	39	30	38	30	

Comparative yearly lighting energy cost per 1000 lumens – **\$2.96** based on 3000 hrs. and \$.08 pwr KWH.

The photometric results were obtained in the Philips Day-Brite laboratory which is NVLAP accredited by the National Institute of Standards and Technology.

Photometric values based on test performed in compliance with LM-79.

sample applications

Spacing	Number of Luminaires	Model	Maintained Average Illumination	Max./Min.	Input Power per lum.	Watts/ Sq. foot
Open Area						
8'x8'	15	2DLG27L840-2-D	30.7 fc	2.1	31W	0.48
		2DLG34L840-2-D	38.8 fc	2.1	39W	0.61
		2DLG38L840-2-D	43.6 fc	2.2	45W	0.70
		2DLG44L840-2-D	50.7 fc	2.1	54W	0.84
8'x10'	15	2DLG27L840-2-D	28.8 fc	1.8	31W	0.48
		2DLG34L840-2-D	36.5 fc	1.8	39W	0.61
		2DLG38L840-2-D	41.0 fc	1.8	45W	0.70
		2DLG44L840-2-D	47.7 fc	1.8	54W	0.84
10'x10'	12	2DLG27L840-2-D	23.2 fc	2.0	31W	0.39
		2DLG34L840-2-D	29.4 fc	2.0	39W	0.49
		2DLG38L840-2-D	33.1 fc	2.0	45W	0.56
		2DLG44L840-2-D	38.4 fc	2.0	54W	0.68
10'x12'	12	2DLG27L840-2-D	21.7 fc	1.7	31W	0.39
		2DLG34L840-2-D	27.5 fc	1.7	39W	0.49
		2DLG38L840-2-D	30.9 fc	1.7	45W	0.56
		2DLG44L840-2-D	35.9 fc	1.7	54W	0.68
Corridor						
12'	9	2DLG27L840-2-D	19.6 fc	1.9	31W	0.56
		2DLG34L840-2-D	24.8 fc	1.9	39W	0.70
		2DLG38L840-2-D	27.8 fc	1.9	45W	0.81
		2DLG44L840-2-D	32.3 fc	1.9	54W	0.97
14'	8	2DLG27L840-2-D	16.9 fc	2.6	31W	0.50
		2DLG34L840-2-D	21.4 fc	2.6	39W	0.62
		2DLG38L840-2-D	24.1 fc	2.6	45W	0.72
		2DLG44L840-2-D	28.0 fc	2.6	54W	0.86
16'	7	2DLG27L840-2-D	15.0 fc	3.3	31W	0.43
		2DLG34L840-2-D	18.9 fc	3.3	39W	0.55
		2DLG38L840-2-D	21.3 fc	3.3	45W	0.63
		2DLG44L840-2-D	24.8 fc	3.3	54W	0.76

Open Area:

The controlled high angle lighting distribution of DualLED provides diffuse uniform lighting in large spaces and creates significant vertical illumination. Wide luminaire spacing is possible.

A sample area:

40' long x 24' wide x 9' ceiling
 80/50/20 reflectances
 Calculation grid at 2.5'
 Maintenance factors 0.85 LLD, 0.94 LDD, 0.799 LLF

Uniformity is excellent at 2.2 or less, even when moving to extended 10'x12' luminaire spacing. High delivered lumen options allow the extended spacing to provide IES recommended illumination levels for many tasks. Smooth, uniform lighting at recommended light levels with good vertical illumination is available with power density between 0.5 and 0.85 Watts per square foot, satisfying any known energy codes.

Corridor:

DualLED allows uniform corridor lighting with wide luminaire spacing and good vertical illumination with reduced scalloping.

A sample corridor:

100' long x 5' wide x 9' ceiling
 80/50/20 reflectances
 Calculation grid at 2.5'
 Maintenance factors 0.85 LLD, 0.94 LDD, 0.799 LLF

Uniformity is excellent at less than 3 to 1 with 12' or 14' spacing and only 3.3 to 1 at extended 16' spacing. Smooth, uniform lighting at recommended light levels with good vertical illumination is available with power density less than 0.5 Watts per square foot.



©2012 Philips Day-Brite
 All rights reserved.
 776 South Green Street • Tupelo, MS 38804
 p. 800.234.1890 • f. 662.841.5501 • www.daybrite.com
 Canadian Division
 189 Bullock Drive • Markham, Ontario L3P 1W4
 p. 905.294.9570 • f. 905.294.9811

Contact Factory for Additional Configurations.
 Specifications are subject to change without notice.
 Consult website for latest version of this spec sheet.