

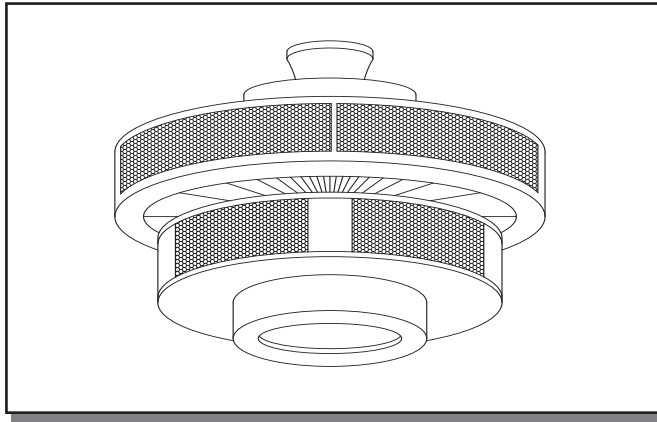

**2 Lamp
UVTT5**



APPLICATION

- Utilizing ultraviolet lamp technology, the Lumalier products kill up to 99.9% of airborne bacteria and viruses, black mold and fungal growth, reduce odors and respiratory allergens, and reduce airborne transmission of influenza, colds, and viruses.

CONSTRUCTION/FINISH

- Durable powder coat finish (Black) is standard.
- Ceiling mount construction. Mounting hardware and canopy included.
- On/off switch is standard.
- Quiet operating 500-cfm air mover unit designed to ensure 360-degree flow of disinfected air.
- Gloves and safety glasses included in each order.
- Tamper resistant hardware available as an option. (Tamperproof Torx drive screwdriver required for installing tamper resistant hardware.)
- Shipping weight is 20 lbs./ 9.1kg.
- Minimum mounting height is 8'8".

ELECTRICAL

- Class P, HPF, CBM certified ballasts comply with ©Federal Ballast Law (Public Law 100-357, 1988).
- 120-277 VAC 50/60 Hz operation using UNV ballasts.
- Equipped with UV PL-L 18W self-starting, compact, 8,000-hour lamps.
- 360-degree irradiation zone.

ACCESSORIES

- **TPDTH** – Torx head pin driver (sold separately)

CATALOG NUMBER

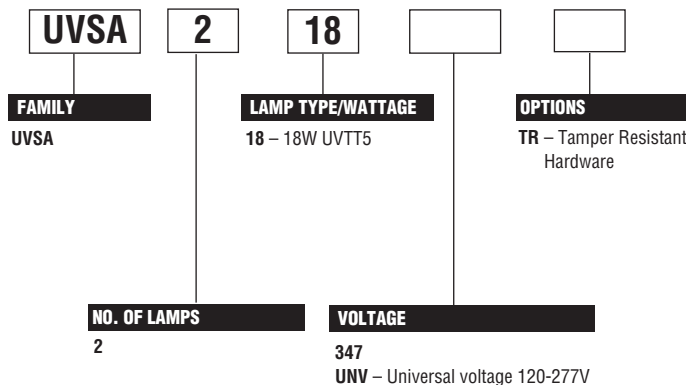

SANITIZING AIR MIXER

DIMENSIONS

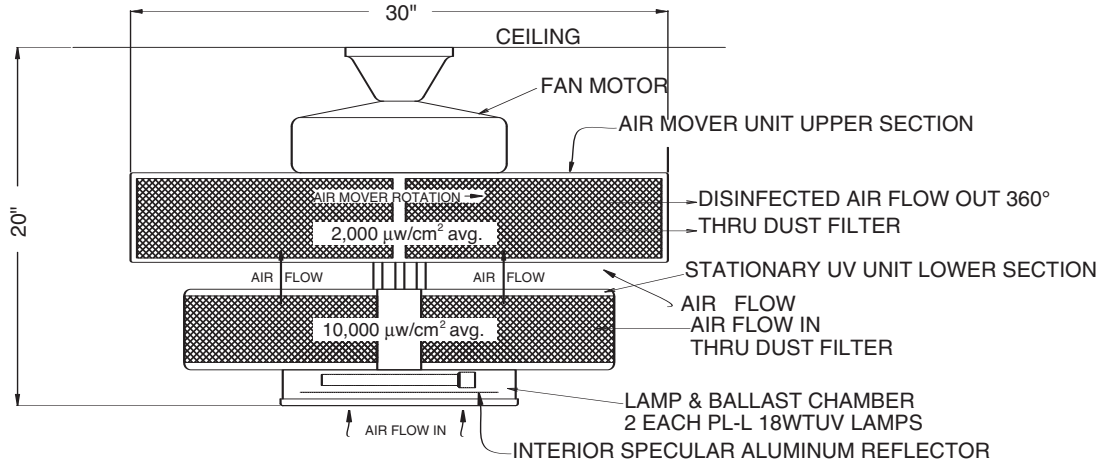

COVERAGE AREA

