

# mcPhilben®

emergency lighting

DEB-3W Fluorescent Emergency Ballast 1450 - 3500 Lumens



Job Name: \_\_\_\_\_

Type: \_\_\_\_\_

Voltage: \_\_\_\_\_

- Damp location listed.
- End-of-lamp-life compatible.
- One or two lamp operation

### CODES AND STANDARDS

UL Listed in accordance with the standards set forth in UL924  
 NFPA 70 (NEC)  
 NFPA101 (Life Safety Code)  
 UL Listed for Damp Locations

### APPLICATION

The DEB-3W Series fluorescent emergency ballast works in conjunction with the AC ballast to convert new or existing fluorescent luminaires into emergency lighting. The emergency ballast consists of a field-replaceable nickel cadmium battery, charger and electronic circuitry in one case. This emergency ballast can be used with most 17 watt through 215 watt (2'-8') T8, T9, T10, or T12 fluorescent lamps without integral starters, including U-shaped, HO, VHO, circline, energy saving, and (4-pin) twin, quad, and triple twin-tube compacts. It is also compatible with most 1, 2, 3, and 4-lamp electronic, standard, energy saving, and dimming AC ballasts including those with end of life lamp detection. If used in an emergency-only luminaire, no AC ballast is necessary. Suitable for indoor and damp locations and for sealed and gasketed fixtures including installation inside of fixtures rated for wet locations. It is not suitable for installation in wet locations, hazardous locations or for air handling air outlet applications.

### OPERATION

When AC power fails, the DEB-3W Series immediately switches to the emergency mode, keeping either one or two lamps illuminated up to 3500 lumens for a minimum of 90 minutes. When AC power is restored, the DEB-3W Series automatically returns to the charging mode.

### BATTERY

The DEB-3W Series uses a sealed maintenance free, nickel cadmium battery equipped with a quick connect plug for easy installation. This battery requires no maintenance, and has a life expectancy of 7 to 10 years. The suggested operating temperature range is 32°F (0°C) to 122°F (50°C).

### RESTRICTIONS

Suitable for indoor and damp locations and for sealed and gasketed fixtures including installation inside of fixtures rated for wet locations. It is not suitable for installation in wet locations, hazardous locations or for air handling air outlet applications.

### EMERGENCY ILLUMINATION

Depending on the lamp number (1 or 2), wattage, and type of lamps selected, the DEB-3W Series produces 1450 to 3500 lumens initial emergency light output. If two-lamp operation is selected, light output is evenly divided between the lamps for better distribution of emergency illumination.

### INSTALLATION

This emergency ballast does not affect normal luminaire operation and may be used with either a switched or unswitched luminaire. If a switched luminaire is used, an unswitched hot lead must be connected to the emergency ballast. The emergency ballast must be fed from the same branch circuit as the AC ballast. The DEB-3W Series may be installed on top of or remote from the luminaire. The emergency ballast may be remote-installed up to half the distance the AC ballast manufacturer recommends removing the AC ballast from the lamp, or up to 50 feet, whichever is less. Installation is not recommended with luminaires where the ambient temperature may fall below 0°C for extended periods. A charging indicator light and double pole test switch are provided. Upon request, a single pole test switch/monitor plate is provided for remote installation of the test switch and charging indicator.

### Ordering Information

**DEB-3W** - 3500 Lumen Max Output Emergency Ballast with Damp Location Listing (0°C to 55°C)

### Accessories

**MCCAPS** - Wire Bundle Kit for External Mounting

**PL-SP** - Single-Pole Remote Test Switch

For factory installed DEB-3W use suffix number -E3 on luminaire catalog number

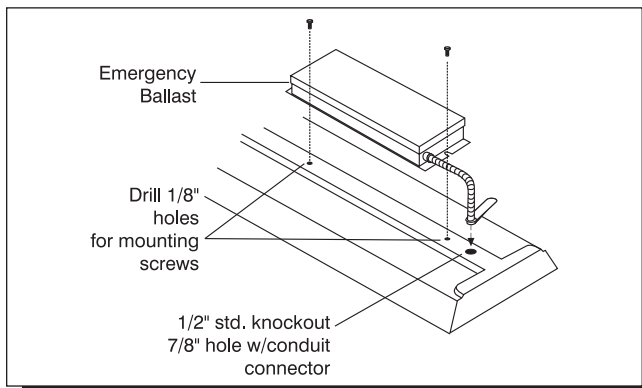

mcPhilben is a Philips group brand

**PHILIPS**

erb3015.4

# DEB-3W Fluorescent Emergency Ballast 1450 - 3500 Lumens

## SUGGESTED SPECIFICATION

Emergency lighting shall be provided by using a standard fluorescent luminaire equipped with a DEB-3W Series emergency ballast. This emergency ballast shall consist of a field-replaceable, high-temperature, maintenance-free nickel cadmium battery, charger and electronic circuitry contained in one 16-5/16" x 5-1/2" x 1-3/4" metal case with a 2' length of flexible conduit. A solid-state charging indicator light to monitor the charger and battery, a double-pole test switch, and installation hardware shall be provided. The emergency ballast shall be capable of operating (one or two) \_\_\_\_\_

fluorescent lamp(s) at \_\_\_\_\_ Lumens initial light output in the emergency mode for a minimum of 90 minutes. This emergency ballast shall have 8 watts maximum of input power, 57.6 watt-hour battery capacity, and exceed emergency standard set forth by the current NEC. The emergency ballast shall be UL Listed for installation inside, on top of, or remote from the luminaire, warranted for a full five years from date of purchase, and is made in the U.S.A.

## ELECTRICAL & MECHANICAL

- Dual input voltage 120/277
- Electrical rating—7 watts
- AC input current—280 mA
- Recharge time—24 hours
- Test switch provided
- Charging indicator light provided—LED
- Ballast case dimensions—16.3" x 5.5" x 1.7"
- Battery is a high temperature nickel cadmium type requiring no maintenance and life expectancy of 7 to 10 years.
- Weight—8.7 lbs.

## WARRANTY

Five year warranty on unit from date of purchase.

**Table 1 - Lamp Compatibility**

Lamp (T8, T10, T12)	Base	Wattage (Length)	No. of Lamps (EMERGENCY)
1", 1-3/4", 1-1/2"	Single or Bipin	17-40W (2'-4')	1
		40-215W (5'-8')	2
Long Compact	4-PIN (2G11)	18-39W	1
			2
		40-55W	1
Twin/Quad/Triple	4-PIN	18-42W	1
Twin-Tube Compact	(G24q, GX24q)		2
2D	4-PIN (GR10q)	16-38W	1
			2
		55W	1
T5	HO Circline 4-PIN (2GX13)	22-55W	1
	Linear Miniature Bipin	14-54W	1

**Table 2 - Initial Lumen Output**

Lamp	LUMENS	
	1 Lamp	2 Lamps
F025, FBO24 T8	2500	2600
F032, FBO31 T8	3000	3000
F040 T8	2400	
F096 T8	3000	3000
F40 T12, F40/U	3000	2700
F40 T12/ES (34W)	2700	
F48 T12/HO	3000	
F96 T12	2800	
F96 T12/HO	2900	
F96 T12/VHO	3300	
PL-L 24W, F27/24BX, DULUX L 27W	1800	2300
PL-L 36W, F39/36BX, DULUX L 39W	2900	3500
PL-L 40W, F40/30BX, F50BX, DULUX L 55W	1800	
F28 2D/4P	2050	2800
F38 2D/4P	2800	2800
FP28T5/HO	1850	
FP39TF/HO	2100	
FP54T5/HO	2650	
FPC55T5/HO	2300	

## WIRING DIAGRAM

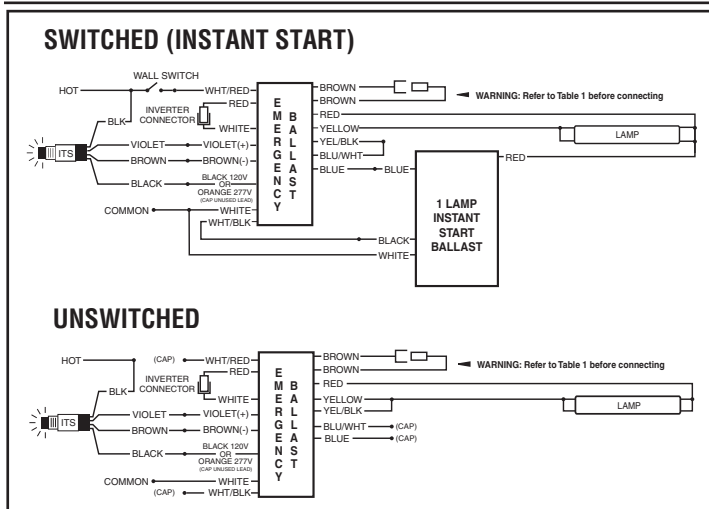

## DIMENSIONS

