

**Emergency Unit**

**Patron LED Series**  
Die-Cast Aluminum  
Mini Wall Light/Unit



**codes and standards**

- ETL Listed to UL924 Standard
- ETL Listed to UL1598 for wet locations
- NFPA 70 (NEC)
- NFPA 101 (Life Safety Code)
- "ARRA" Buy American Compliant (when -BAC suffix is specified)
- ADA Compliant
- LM-79 Compliant
- LM-80 Compliant

**construction**

- Marine-grade die-cast aluminum housing with mirror reflector to provide excellent photometrics. UV Stable polycarbonate lens and neoprene gasket to protect from moisture and rain.
- Polyester powder coat for superior protection. Choice of white or dark bronze. Consult factory for custom finishes.

**installation**

- Universal J-box pattern on back or rigid conduit entry on top of housing for mounting flexibility

**electronics**

- ent battery drain prior to the energizing of utility power, and brownout protection which will automatically switch unit into emergency mode if the utility power sags below 80% of nominal. Solid-state, fully automatic charging circuit is protected with a moisture-resistant coating. All units are provided with Self-Test/Self Diagnostics. (Not available in Remote Units.)
- 120/277VAC dual voltage input, selectable input.
- Patron LED available in AC only, Emergency only, and AC with integral ni-cad battery operation may be switched on or off to operate as a mini wall light providing 740 lumens in AC mode. AC with integral ni-cad battery and emergency only will provide 500 lumens in emergency mode.

**lamps**

- 8-3W LED lamps provide 700 lumens in the AC mode and provide 500 initial lumens in the emergency mode. Color temperature is 4500K and provides over 50,000 hours of life in normal usage.

**battery**

- AC with integral ni-cad battery and emergency units contain a 6V maintenance-free sealed nickel cadmium

battery with an expected service life of 8-12 years and an operating temperature of -4°F (20°C) to 122°F (50°C). Units with a battery provide a minimum of 90 minutes emergency illumination. Units with a heater will operate in temperatures as low as -20°F (-29°C).

**warranty**

- Five full year warranty on units

**self-diagnostic/self-test**

- This feature provides automatic testing and continuous monitoring of the unit and indicates any faults via a dual-color LED lamp. The low-profile test button with easily visible status indicator is located beneath the lens.
- This innovative circuitry monitors battery disconnection, charger failure, lamp failure and transformer fault every 5 seconds without discharging the battery or illuminating the lamps. It will automatically indicate lamp, battery, and charger status by dual-color LED lamp.

The LED lamp indicator shows the following status:

- Green - ON: Unit is ready.
- Blinking: Unit is self-testing.
- Red - Service Alert (see fault indications)

Fault Indications: (Red LED lamp indicator)

- One blink ON/pause 4 seconds: Battery not connected.
- Two blinks ON/pause 4 seconds: Battery is shorted or battery voltage drops below the accepted value.
- Three blinks ON/pause 4 seconds: Charger board circuit fault.
- Four blinks ON/pause 4 seconds: Transformer fault.
- Five blinks ON/pause 4 seconds: Lamp fault.

The unit will automatically initiate a self-test as follows:

- One minute self-test each month.
- 30 minute self-test on the 6th month following installation.
- 90 minute self-test on the 12th month following installation.

Manual testing of the unit can be accomplished by pressing the test button as follows:

- Once - 1 minute test
- Twice - 5 minute test
- Three - 30 minute test
- Four - 90 minute test

**Specifier's Reference**

Project
Type
Model No.
Comments

Catalog Number	Operation	Volts	LED	Housing Finish	Lamp Type
<b>PLACBZ</b>	AC only	6	8-3W	Dark Bronze	700 Lumen Output
<b>PLACW</b>	AC only	6	8-3W	White	700 Lumen Output
<b>PLEMBZ</b>	EM only	6	8-3W	Dark Bronze	500 Lumen Output
<b>PLEMW</b>	EM only	6	8-3W	White	500 Lumen Output
<b>PLACEMBZ*</b>	AC/EM	6	8-3W	Dark Bronze	700/500 Lumen Output
<b>PLACEMW*</b>	AC/EM	6	8-3W	White	700/500 Lumen Output
<b>PLACB-BAC</b>	AC only	6	8-3W	Black	700 Lumen Output
<b>PLACTT-BAC</b>	AC only	6	8-3W	Titanium	700 Lumen Output
<b>PLACCC-BAC**</b>	AC only	6	8-3W	Custom Color	700 Lumen Output
<b>PLEMB-BAC</b>	EM only	6	8-3W	Black	500 Lumen Output
<b>PLEMTT-BAC</b>	EM only	6	8-3W	Titanium	500 Lumen Output
<b>PLEMCC-BAC**</b>	EM only	6	8-3W	Custom Color	500 Lumen Output
<b>PLACEMB-BAC*</b>	AC/EM	6	8-3W	Black	700/500 Lumen Output
<b>PLACEMTT-BAC*</b>	AC/EM	6	8-3W	Titanium	700/500 Lumen Output
<b>PLACEMCC-BAC**</b>	AC/EM	6	8-3W	Custom Color	700/500 Lumen Output

\*AC mode for general lighting with an integral nicad battery for emergency illumination.

\*\*Must provide RAL# for custom color.

**Accessories (order separately)**

**PLHTR** Patron Heater Kit  
**WG3** Wire Guard

**Option**  
**BAC**

Buy American Compliant

**dimensions**

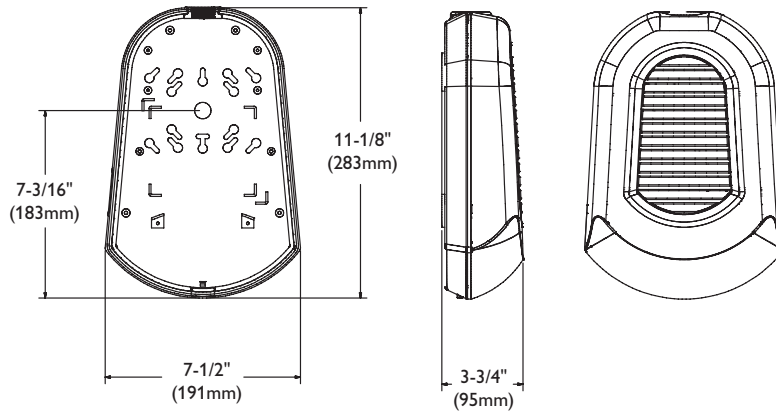

**photometrics**

Meets Life Safety Code standard minimum illuminance of 0.1 FC and average illuminance of 1.0 FC. Indoor performance based on 80/50/20 reflectance and assumes open space with no obstructions. Refer to charts for mounting height. Add 1' to mounting height for ceiling height. Outdoor performance based on 0/30/10 reflectance. Analysis based on independently tested photometrics.

Reflectance
<b>Indoor: 80/50/20</b>
<b>Outdoor: 0/30/10</b>

**Single Unit**

	MH	W	L	Average Footcandle
	Mounting Height	Path of Egress		
		Width	Length	
Indoor	9'	10'	41'	1.22
	11'	6'	43'	1.25
Outdoor	9'	10'	39'	1.83
	11'	6'	41'	1.20

**Single Unit Forward Path of Egress**

	MH	W	L	Average Footcandle
	Mounting Height	Path of Egress		
		Width	Length	
Outdoor	10'	6'	24'	2.35
	12'	6'	27'	1.78
	14'	6'	37'	1.11

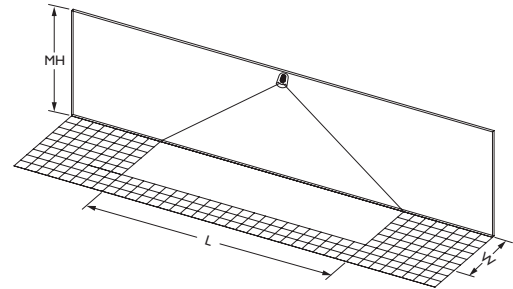
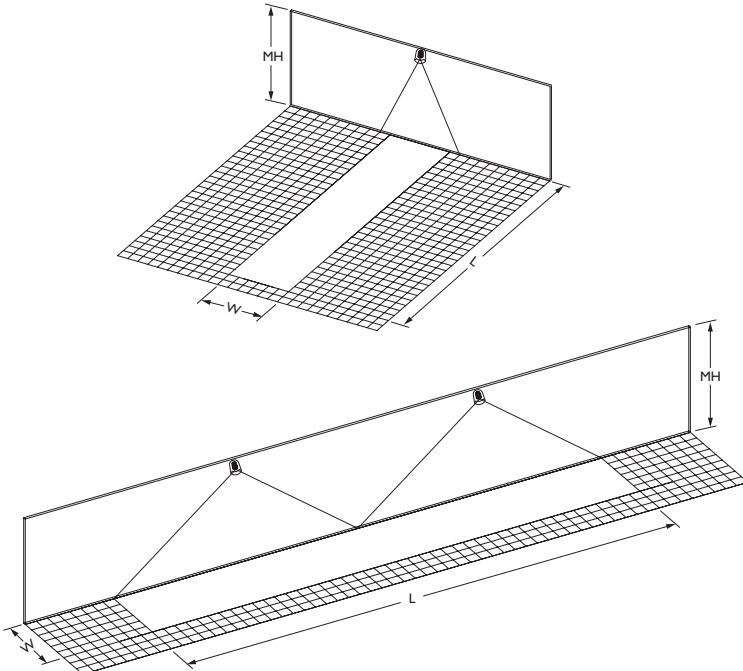

**Two Units Center-to-Center Spacing**

	MH	W	L	Average Footcandle
	Mounting Height	Path of Egress		
		Width	Length	
Indoor	8'	6'	49'	1.76
	11'	6'	62'	1.04
	11'	10'	47'	1.07
	14'	6'	54'	1.17
Outdoor	9'	6'	43'	1.55
	11'	6'	55'	1.00
	11'	10'	42'	1.00
	14'	6'	40'	1.14



©2012 Philips Day-Brite  
 All rights reserved. Revised June 2011.  
 776 South Green Street • Tupelo, MS 38804  
 p. 800.234.1890 • f. 662.841.5501  
 Canadian Division  
 189 Bullock Drive • Markham, Ontario L3P 1W4  
 p. 905.294.9570 • f. 905.294.9811

Contact Factory for Additional Configurations.  
 Specifications are subject to change without notice.