

CLE and CLC

Track Limiters

Catalog Number: _____

Type _____

Project: _____



Description

Considering the lighting technology available today, connected loads on a track system may be far less than watts per linear foot requirements of National, State or local energy codes. Capri's track limiter is a device which limits current lowering the actual VA rating of each track lighting circuit. By limiting the amount of current, or wattage on a track circuit through a tamper proof electrical device, actual connected loads may be less than standard linear foot computations required by many energy conservation codes.

When lighting changes and flexibility are required, Capri's line voltage, low voltage, compact fluorescent and ceramic arc metal halide track lighting systems, along with Capri's track limiters, will provide solutions while supporting energy conservation.

Features

- Plastic polycarbonate wire cover and housing.
- Galvanized steel mounting plate.
- Two 7/8" knockouts for electrical feed. 1 or 2 circuits can be fed into connector. Knock outs are offset to accommodate T-grid ceiling runners.
- Track connectors are keyed and polarized to maintain proper continuity with track. Installs into track end providing electrical and mechanical connection.
- Tamper proof locking screws secure the connector to track.
- Track limiter is designed to control the actual load applied to a track circuit thereby allowing the limiter's applicable VA rating to be used for lighting density calculations.

CATALOG SYSTEM AND OPTIONS

SAMPLE CATALOG NUMBER: CLE13W

CLE- THROUGH CEILING END FEED

Single Circuit - CLE	Two Circuit - CLE	Finishes
CLE11 120 VA Rated Track Limiter	CLE21 (2)120 VA Rated Track Limiter	W White
CLE13 360 VA Rated Track Limiter	CLE23 (2)360 VA Rated Track Limiter	BK Black
CLE15 600 VA Rated Track Limiter	CLE25 (2)600 VA Rated Track Limiter	SL Silver
CLE17 840 VA Rated Track Limiter	CLE27 (2)840 VA Rated Track Limiter	
CLE110 1200 VA Rated Track Limiter	CLE210 (2)1200 VA Rated Track Limiter	

CLC- END FEED WITH COVER

Single Circuit - CLC	Two Circuit - CLC	Finishes
CLC11 120 VA Rated Track Limiter	CLC21 (2)120 VA Rated Track Limiter	W White
CLC13 360 VA Rated Track Limiter	CLC23 (2)360 VA Rated Track Limiter	BK Black
CLC15 600 VA Rated Track Limiter	CLC25 (2)600 VA Rated Track Limiter	SL Silver
CLC17 840 VA Rated Track Limiter	CLC27 (2)840 VA Rated Track Limiter	
CLC110 1200 VA Rated Track Limiter	CLC210 (2)1200 VA Rated Track Limiter	

General Notes:

Use the VA strength that coordinates with the installed track voltage.

SPECIFICATIONS

- Mounting** - End feed mounts directly to surface through ceiling wiring. Cover plate end feed mounts directly to 4 inch octagonal handy box (by others).
- Construction** - Track limiter housing constructed of injection molded polycarbonate. Housing is attached to back plate via tamper proof screws. Back plate constructed of galvanized steel.
- Electrical** - Operates on nominal 120vac. Integral switchable thermal circuit breaker combines on/off switch

and circuit protection for specified load. Device will interrupt power based on time versus current trip when specified load is exceeded. Nominal time of circuit interruption calculated when operating at nominal 77 degrees Fahrenheit or 25 degrees Celsius. For circuit interruption on alternate temperatures, please review the included Ambient Compensation Chart. All Capri track components are polarized and continuously grounded throughout. Electrical connections are concealed in an isolated liner. Intended for wiring to branch circuit building wire with ground. All wiring must be in accordance with National and local building codes.

4. **Labels**- UL listed. Product is designed to meet California Title 24, AHSRAE, the International Energy Conservation Committee and other applicable energy restrictions.

5. **Finishes**- Choice of W (white), BK (black), or SL (silver).

DIMENSIONS - CLE

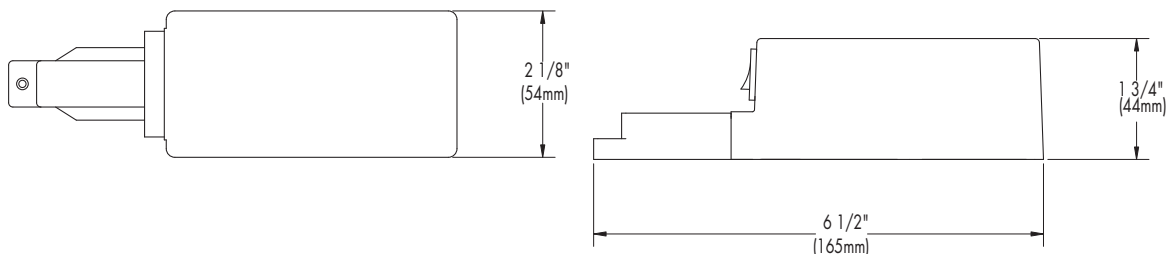

REV. 11/07

DIMENSIONS - CLC

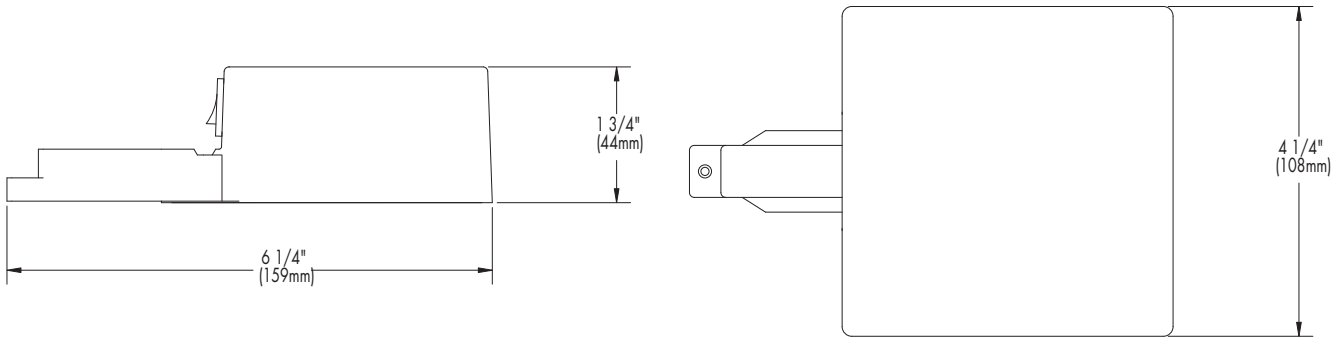

Typical Resistance vs. Current Rating @ 25 = 25°C

Current Rating in Amps	Typical Resistance in Ohms
1.0	0.89
3.0	0.069
5.0	0.030
7.0	0.017
10.0	0.011

AMBIENT COMPENSATION CHART

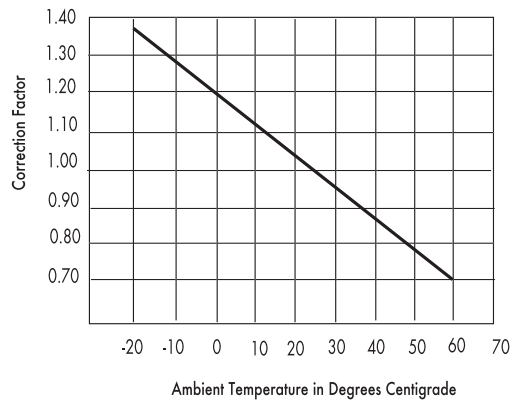

To use this chart: Read up from the ambient temperature to the curve and across to find a correction factor. Multiply the breaker rating by the correction factor to determine the compensated rating. Calculate the overloads in terms of the compensated rating to use the published trip curve. Do not use the devices outside their specified operating temperature ranges.

TIME VS. TEMP CURVE @25°C

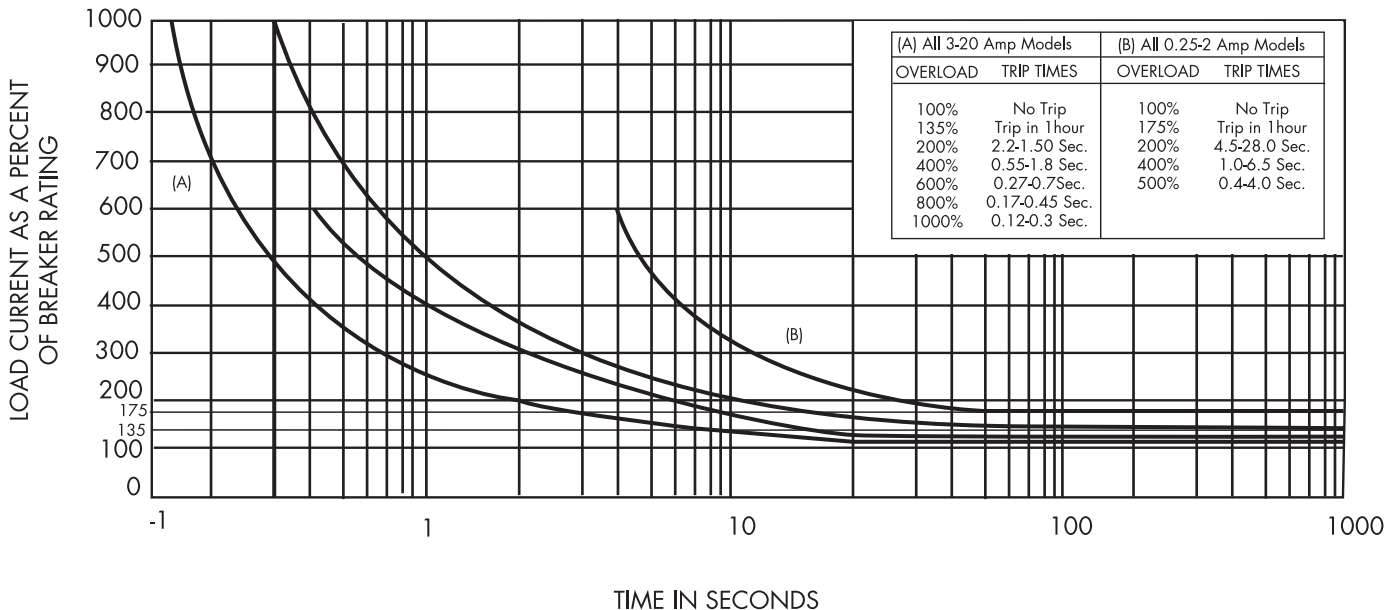

Capri Lighting reserves the right to make changes without notice.©2005